

The logo for Mi.Ka features a stylized white icon of a house with a gabled roof and a small star above it, followed by the text "Mi.Ka" in a clean, white, sans-serif font.

# Mi.Ka

Il design innovativo incontra  
l'ottimizzazione dello spazio

A modern, light-colored modular home with a gabled roof and large windows is situated on a sandy beach. The home is surrounded by tall, golden grasses and a large, mature pine tree. The ocean is visible in the background under a blue sky with scattered clouds. A wooden deck with a chair and a small table is in front of the home.

SCOPRI LA COLLEZIONE MI.KA



**Kasa Project** (Soc. Coop.) viene fondata nel 1993.

Vantando ad oggi un'esperienza trentennale nel settore dei prefabbricati in legno, adotta da sempre un metodo di produzione che si avvale di un continuo studio nella progettazione e nella ricerca dei materiali.

Essendo costruttori diretti cerchiamo di creare soluzioni abitative ad hoc, in grado di rispondere a qualsiasi esigenza con stile e versatilità, in perfetta sintonia con le richieste del cliente.

Grazie all'attento lavoro di preassemblaggio all'interno dei nostri laboratori, siamo in grado di ottenere un prodotto di qualità velocemente montabile e curato nei dettagli, che unisce la sensibilità per le tecnologie costruttive più avanzate al sapere artigianale delle nostre maestranze.



# TRAVELLER

Per una sosta quale che sia il tuo viaggio



# ESSENTIAL

La soluzione abitativa entry level

# SKY

Ogni sfumatura del cielo



# MODULAR

La soluzione modulare

 Mi.Ka  
TRAVELLER



**Per una sosta quale che sia il tuo viaggio**

*Dimensioni 280 x 250 cm*



Tre possibili disposizioni dei letti





**Mi.Ka**  
ESSENTIAL



Un rifugio, per lasciare ogni complicazione e vivere nella natura



*Dimensioni: 550 x 250 cm*



Disponibile in versione Lodge con cucina e Hotel solo pernottamento

The logo for Mi.Ka SKY features a stylized icon of a house with a star above it, followed by the text "Mi.Ka" in a large, bold, sans-serif font, and "SKY" in a smaller, all-caps, sans-serif font below it.

**Mi.Ka**  
SKY

A modern, dark grey cabin with large glass windows and a wooden deck. The interior is visible through the glass, showing a living area with a sofa and a dining table. The cabin is situated in a grassy field with trees in the background.

**Vivere ogni sfumatura del cielo con il comfort abitativo di una suite**



*Dimensioni 700 x 300*

Disponibile in versione  
Lodge con cucina e  
Hotel solo pernottamento

---



La soluzione modulare che progettiamo  
insieme per rispondere a ogni vostra  
esigenza abitativa.

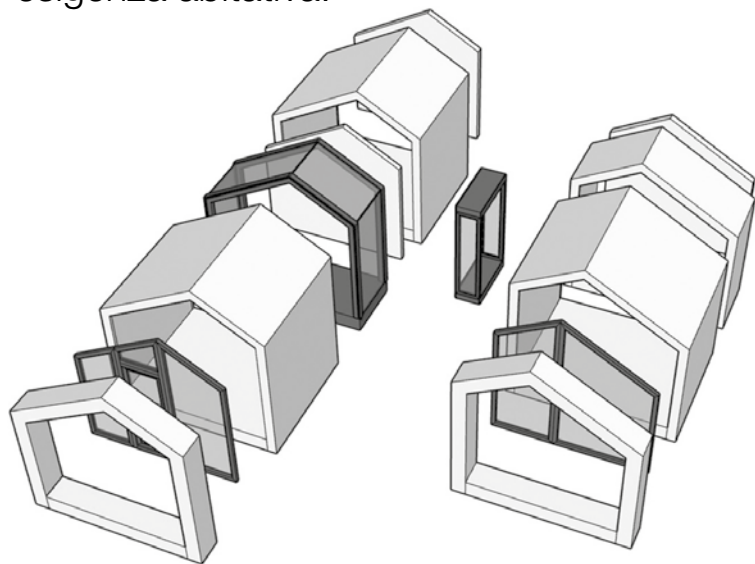

Esempio di soluzione  
4 + 2 posti letto





Il design innovativo incontra  
l'ottimizzazione dello spazio



## **Kasa Project** (Soc. Coop.)

Via Fossale, 4  
10013 Borgofranco d'Ivrea (To)

Tel. 0125 751921

[www.kasaproject.it](http://www.kasaproject.it)

email: [info@kasaproject.it](mailto:info@kasaproject.it)

P. IVA 11854760011

